



Length	958 mm
Width	680 mm
Height	34 mm
Frame	Aluminum
Weight	7,6 kg

# Sunmodule®

## SW 80 poly RNA

### World class quality

SolarWorld produces the best products with the highest quality, manufactured according to German and US quality standards in fully-automated ISO 9001 and 14001 certified factories.

### Efficell® – Made in Germany

High-efficiency SolarWorld poly cells are made in Germany for maximum performance and quality.

### Independently proven to produce more energy

Independent testing carried out by the Photon trade magazine in 2008 and 2009 showed that SolarWorld modules produced up to 12% more kilowatt-hours than other major brands.

### An experienced industry leader

With over 30 years of experience in off-grid solar applications – SolarWorld delivers top products and technical experience at the highest levels. Our modules are installed in over 100,000 Telecom/Industrial systems worldwide. Nobody else comes close.



# Sunmodule®

## SW 80 poly RNA

### PERFORMANCE UNDER STANDARD TEST CONDITIONS (STC)\*

		SW 80
Maximum power	$P_{max}$	80 Wp
Open circuit voltage	$U_{oc}$	21,9 V
Maximum power point voltage	$U_{mpp}$	17,9 V
Short circuit current	$I_{sc}$	4,78 A
Maximum power point current	$I_{mpp}$	4,49 A

\*STC: 1000W/m<sup>2</sup>, 25°C, AM 1.5

### PERFORMANCE AT 800 W/m<sup>2</sup>, NOCT, AM 1.5

		SW 80
Maximum power	$P_{max}$	58,0 Wp
Open circuit voltage	$U_{oc}$	19,7 V
Maximum power point voltage	$U_{mpp}$	16,1 V
Short circuit current	$I_{sc}$	3,85 A
Maximum power point current	$I_{mpp}$	3,59 A

Minor reduction in efficiency under partial load conditions at 25°C: at 200W/m<sup>2</sup>, 95% (+/-3%) of the STC efficiency (1000 W/m<sup>2</sup>) is achieved.

### COMPONENT MATERIALS

Cells per module	36
Cell type	Poly crystalline
Cell dimensions	94 mm x 156 mm
Front	tempered glass (EN 12150)

### SYSTEM INTEGRATION PARAMETERS

Maximum system voltage SC II	1000 V
Maximum reverse current	12 A
Number of bypass diodes	2

### THERMAL CHARACTERISTICS

NOCT	46 °C
TC $I_{sc}$	0,034 %/K
TC $U_{oc}$	-0,34 %/K
TC $P_{mpp}$	-0,48 %/K

### ADDITIONAL DATA

Power tolerance	-5 / +10 %
Junction box	IP65
Maximum outer cable diameter	6,9 mm
Maximum wire cross section	4 mm <sup>2</sup>

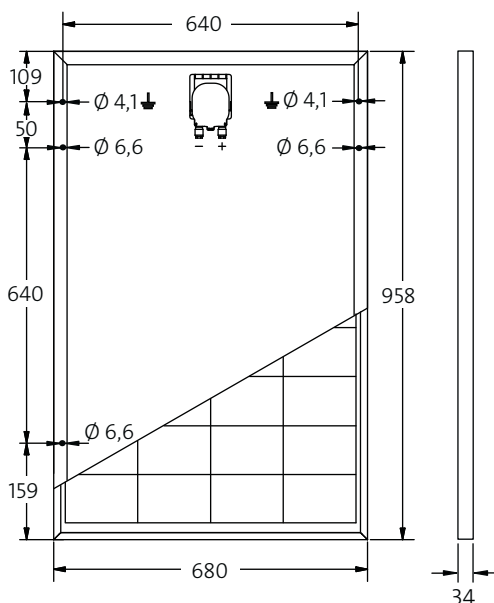

- Qualified, IEC 61215
- Safety tested, IEC 61730
- Periodic Inspection

